



Westport

EVERY™ ALTERNATIVE. B GAS PLUS



NATURAL GAS ENGINES FOR TRUCK AND BUS

A CLEAR AND POWERFUL ALTERNATIVE.

B GAS PLUS

The Cummins Westport B Gas Plus is a 5.9-liter six-cylinder natural gas engine that builds on the rugged, reliable design of Cummins diesel engines, particularly the venerable Cummins B Series, one of the most successful engine designs ever built. The B Gas Plus delivers robust, dependable power from 195 to 230 hp with ultra-low emissions and proven reliability. It features drive-by-wire and enhanced controls, plus full-authority electronics that include a programmable Electronic Control Module (ECM) that sets engine operating parameters and provides for road speed governing, engine protection and complete self-diagnostics. The B Gas Plus is known for excellent torque, high fuel efficiency and uncompromising performance.

This reliable performer is ideal for shuttles, buses, local pickup and delivery trucks, step vans, yard spotters, street sweepers and other medium-duty applications. The B Gas Plus is offered in over 100 different models of trucks and buses manufactured by North American and international companies. Worldwide, more than 4,000 engines are in service.

The B Gas Plus is also designed for either compressed (CNG) or liquefied (LNG) natural gas vehicles, using methane number 65 or greater. For propane vehicles, the B LPG Plus is also available.

Specifications.

The B Gas Plus combines these performance advantages with ultra-low emissions – certified with a catalyst – to U.S. EPA 2005 standards, California Air Resources Board optional low-NOx+NMHC (1.8 g/bhp-hr) certification and low-PM (Particulate Matter) standards. B Gas Plus PM emissions meet the 2010 EPA standards today. For international markets, the B Gas Plus is also certified to Euro III standards.

It features lean-burn spark-ignited combustion. Curves shown represent gross engine performance capabilities obtained and corrected in accordance with Cummins standards. Standard conditions are: 29.36 in. Hg (99.14 kPa) barometric pressure (500 ft [152 m] altitude, 77°F [25°C] inlet air temperature). Actual performance may vary with different ambient conditions.



Ratings

ENGINE MODEL	ADVERTISED HP (KW) @ RPM	PEAK TORQUE LB-FT (N•M) @ RPM	GOVERNED SPEED
BG-230	230 (172) @ 2800	500 (678) @ 1600	2800 RPM
BG-200	200 (149) @ 2800	465 (630) @ 1600	2800 RPM
BG-195	195 (145) @ 2800	420 (569) @ 1600	2800 RPM
BLPG-195	195 (145) @ 2800	420 (569) @ 1600	2800 RPM

Specifications

ADVERTISED HORSEPOWER	195-230 HP	145-172 kW
PEAK TORQUE	420-500 LB-FT	569-678 N•M
GOVERNED SPEED	2800 RPM	
CLUTCH ENGAGEMENT TORQUE	285 LB-FT	386 N•M
NUMBER OF CYLINDERS	6	
BORE AND STROKE	4.02 IN X 4.72 IN	102 MM X 120 MM
ENGINE DISPLACEMENT	359 CU IN	5.9 L
COMPRESSION RATIO	10.5:1	
OPERATING CYCLES	4	
OIL SYSTEM CAPACITY	4.0 U.S. GAL	15.0 L
COOLANT CAPACITY	10.5 U.S. QT	9.9 L
LENGTH	40.0 IN	1016 MM
WIDTH	31.9 IN	809 MM
HEIGHT	33.7 IN	856 MM
NET WEIGHT W/STANDARD ACCESSORIES, DRY	1,018 LB	462 KG
EMISSIONS	1.8 NOx+NMHC 0.01 PM (PM LEVEL MEETS 2010 EPA STANDARDS)	– U.S. EPA 2005 – CARB OPTIONAL LOW NOx (1.8 G/BHP-HR) – EURO III
FUEL TYPE	CNG/LNG	METHANE NUMBER 65 OR GREATER

For more information, call your local Cummins distributor or Cummins Westport representative, or visit www.cumminswestport.com.

Features And Benefits.

- Air/Fuel Regulation – Cummins closed-loop electronic control system is based on Cummins CM556 ECM that sets engine operating parameters and maintains efficient operation using sensors to monitor and control various engine parameters, exhaust backpressure, intake manifold temperature, fuel inlet pressure, knock detection, air-fuel ratio and fuel mass flow.
- Air Intake System – Charge air cooling is utilized to reduce emissions by lowering intake manifold air pressures.
- Accessory Belt Drive System – Self-tensioning serpentine polyvee belt accessory drive system for water pump, engine-mounted fan hub and most alternators. Gear-driven air compressor with provision for gear-driven hydraulic pump.
- Catalyst – Required for all models. Engine is certified to: U.S. EPA 2005, California Air Resources Board optional low NOx (1.8 g/bhp-hr) and Euro III.
- Control System/Electronics – Features full drive-by-wire, enhanced controls and full-authority electronics. The ECM monitors engine sensors, controls fuel and ignition systems, sets engine parameters and provides state-of-the-art data links and the ability to interface with Cummins INSITE™ and QuickCheck diagnostic service tools for fast troubleshooting.
- Crankshaft – Induction-hardened forged-steel crankshaft provides maximum strength and multiple regrind capability for long-term cost savings. Crankshaft is supported by seven main bearings for optimum durability.
- Cylinder Block – Full-skirted block increases rigidity and strength. The design provides superior durability, as well as superior piston ring and bearing life.
- Fuel Tolerance – Designed for compressed (CNG) or liquefied (LNG) natural gas vehicles. Its wide fuel tolerance – down to methane number 65 – increases uptime worldwide.
- Pistons – For extended piston and ring life, a Ni-Resist insert is cast into the aluminum piston and carries the top piston ring.
- Turbocharger – Holset turbocharger with watercooled bearing housing and electronically controlled wastegate provides improved response and performance without sacrificing durability.

Proven “Plus” Technology Maximizes The Equation.

Building on the rugged design of Cummins diesel engines and the “Plus” technology of Cummins Westport, the B Gas Plus features a highly efficient ECM to control its fuel system, engine sensors and high-energy ignition system. It features state-of-the-art data links and the ability to interface with Cummins INSITE and QuickCheck diagnostic service tools for fast troubleshooting. Additional “Plus” technology benefits include full drive-by-wire, programmable engine parameters, multi-speed PTO, cruise control, road speed governing, idle speed control and shutdown, accelerator interlock, engine protection system and more. Life-to-rebuild and rebuildability are the same as a diesel engine.

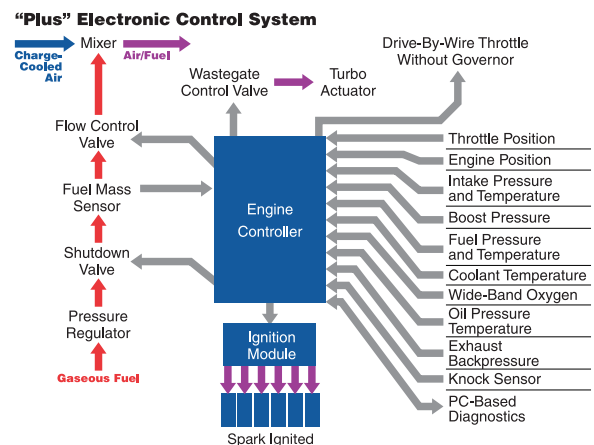

Cummins Westport – Meeting Every Demand For Power.

Cummins Westport is the industry leader in producing high-quality, economical natural gas engines to meet the global demand for clean power. Cummins Westport engines are the proven, reliable power in over 15,000 vehicles worldwide. B Gas Plus NOx emissions levels are 30% lower, and particulate matter emissions are 90% lower than current EPA standards. City fleets worldwide put Cummins Westport B Gas Plus natural gas engines to work – every day.

Warranty. Every Coverage.

Cummins Westport B Gas Plus truck, urban transit bus and shuttle engines come with a standard 2-year/unlimited-mileage warranty with full parts and labor on all warrantable failures.* See your local Cummins distributor or Cummins Westport representative for additional warranty information.

Emissions Warranty – 5 years or 100,000 miles (160,935 km), whichever comes first.

Major Components – A 6-year/300,000-mile (482,804 km) Major Components Protection Plan, designed specifically around the needs of our natural gas engine customers, may be purchased during the engine's first year in service, is transferable at no charge and features no deductible.

*Warrantable failures are those due to defects in materials or workmanship.

Extended Coverage Plans.

A 6-year/300,000-mile (482,804 km) Major Components Protection Plan, designed specifically around the needs of our natural gas engine customers, may be purchased during the engine's first year in service, is transferable at no charge and features no deductible.

For additional details, please contact your local Cummins distributor or Cummins Westport representative.

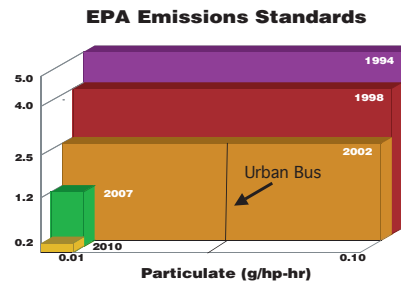

A More Cost-Efficient Way To Meet Every Emissions Challenge.

To meet the new 2007 and 2010 standards set by the EPA and other regulatory bodies targeting NOx, HC and particulate emissions, diesel engine manufacturers will apply advanced technologies, which can increase capital and operating costs. But Cummins Westport is well ahead of the EPA schedule. Cummins Westport natural gas products use technology today that will enable our customers to meet 2010 emissions standards in 2007 with only simple, passive aftertreatment.

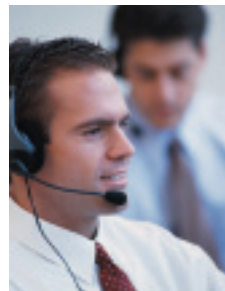

Customer Support. Every Place You Need It.

The total solution Cummins Westport has created combines fuel availability, government programs and funding, plus additional resources to make natural gas

power a viable alternative. Local service, as well as parts availability for Cummins Westport products, is available at any authorized Cummins facility. Cummins global network includes 550 company-owned and independent distributor facilities with more than 5,500 parts and service locations in 160 countries. Cummins distributors provide maintenance schedules, warranty information and product-training support worldwide. On every continent.

Contact the Customer Assistance Center – (1-800-343-7357). Cummins specialists provide technical assistance, service locator and product literature 24 hours/day, 365 days/year.

Europe: (44) 1327 886-464

Australia/New Zealand: 1-800-351-004

Asia: 1-800-810-5252

B GAS PLUS TORQUE AND POWER CURVES.

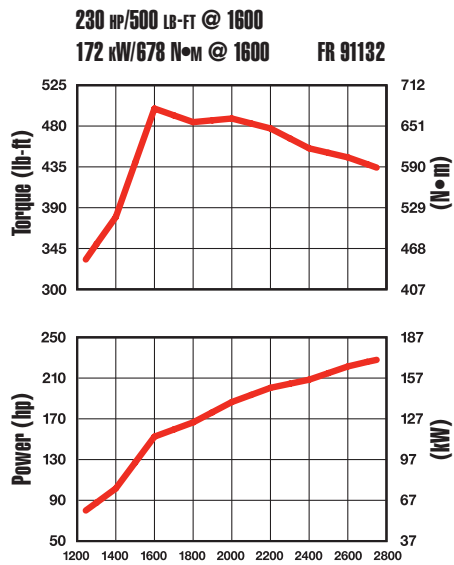
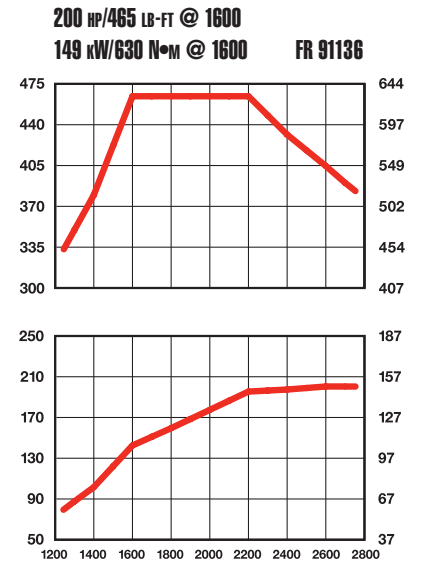
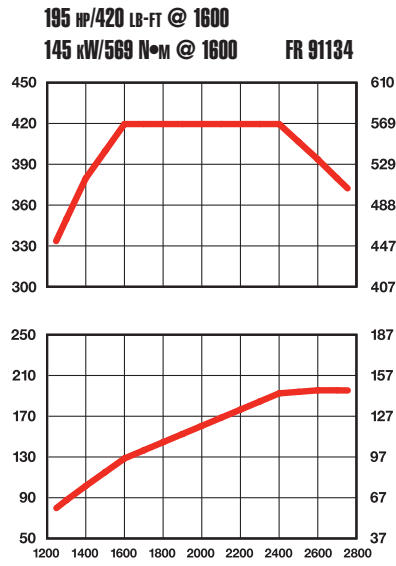
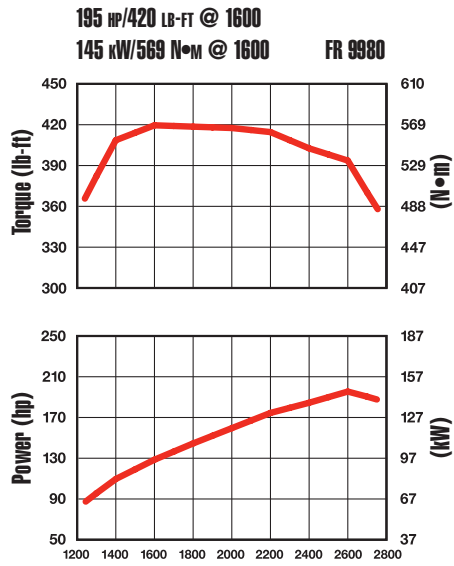



EXPLORE EVERY ALTERNATIVE.

For more information, please contact:



Cummins Westport Inc.
101-1750 West 75th Avenue
Vancouver, B.C.
Canada V6P 6G2

Phone: 604-718-8100
Fax: 604-718-2001
E-Mail: info@cumminswestport.com
Internet: www.cumminswestport.com
www.cummins.com

Bulletin 4103877 Printed in U.S.A. 4/05
©2005 Cummins Westport Inc.